

WIRING INFORMATION

Decoder light functions create the desired effects by controlling the amount and timing of power that is allowed to pass through the decoder to ground. The blue wire is positive 12 volts power. The function wires, white, yellow, green, brown, violet and pink are negative or ground when the function is turned on.

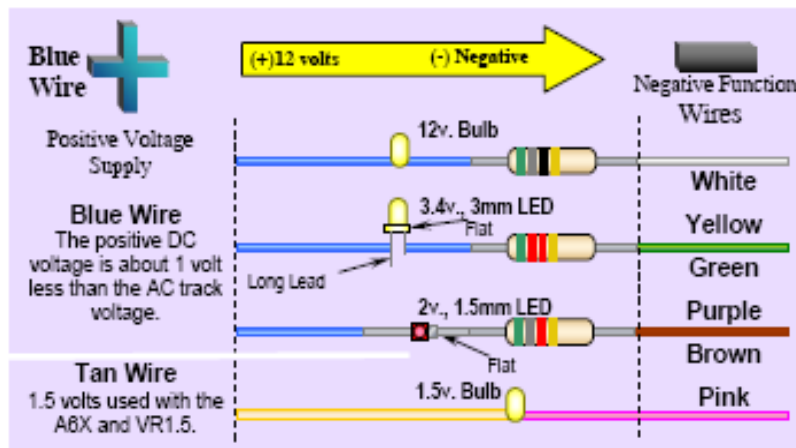

If a LED is installed backward, no damage will be done but the light won't work.

Make sure that the resistor is large enough to absorb all the energy above what the device is rated for. Failure to do this will cause premature or immediate failure. Do not operate on a layout with a higher track voltage than yours.

The following table shows the minimum and a slightly larger recommended resistor for each voltage.

Use 1/4 watt min. resistors unless a * indicates a 1/2 watt resistor is required.

Resistor values

Size and type of device	12v. Track	14v. Track	16v. Track
One 30mA, 12V. Bulb	0 Ω	43 / 47 Ω	110 / 120 Ω
One 15mA, 12V. Bulb	0 Ω	82 / 91 Ω	220 / 240 Ω
One 20mA, 3.4V. White LED	390 / 430 Ω	510 / 560 Ω	620 / 680 Ω
One 20mA, 2V. Colored LED	470 / 510 Ω	680 Ω	680 / 750 Ω^*
One 30mA, 1.5V. Bulb	330 / 360 Ω^*	430 Ω^*	470 / 510 Ω^*
One 15mA, 1.5V. Bulb	680 / 750 Ω	820 / 910 Ω	1000 / 1100 Ω
Two 15mA, 12V. Bulbs in parallel	0 Ω	43 / 47 Ω	110 / 120 Ω
Two 20mA, 3.4V. White LEDs in series	220 / 270 Ω	330 / 360 Ω	430 / 470 Ω
Two 20mA, 2V. Colored LEDs in series	360 / 430 Ω	470 / 510 Ω	620 Ω
Two 15mA, 1.5V. Bulbs in series	560 / 620 Ω	750 Ω	820 / 910 Ω
Three 20mA, 3.4V. White LEDs in series	51 / 56 Ω	160 / 180 Ω	270 / 300 Ω
Three 20mA, 2V. Colored LEDs in series	270 / 300 Ω	360 / 430 Ω	470 / 510 Ω