

WIRING INFORMATION

Decoder light functions create the desired effects by controlling the amount and timing of power that is allowed to pass through the decoder to ground. The blue wire is positive 12 volts power. The function wires, white, yellow, green, brown, violet and pink are negative or ground when the function is turned on.

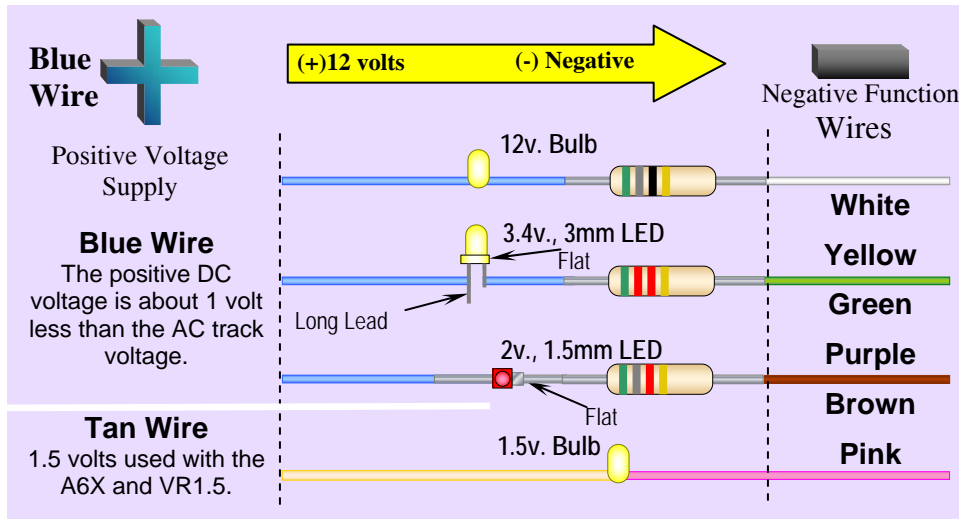

If a LED is installed backward, no damage will be done but the light won't work. Make sure that the resistor is large enough to absorb all the energy above what the device is rated for. Failure to do this will cause premature or immediate failure. Do not operate on a layout with a higher track voltage than yours.

The following table shows the minimum and a **slightly larger recommended** resistor for each voltage.

Use 1/4 watt min. resistors unless a * indicates a **1/2 watt resistor** is required.

Resistor values

Size and type of device	12v. Track	14v. Track	16v. Track
One 30mA, 12V. Bulb	0 Ω	43 / 47 Ω	110 / 120 Ω
One 15mA, 12V. Bulb	0 Ω	82 / 91 Ω	220 / 240 Ω
One 20mA, 3.4V. White LED	390 / 430 Ω	510 / 560 Ω	620 / 680 Ω
One 20mA, 2V. Colored LED	470 / 510 Ω	680 Ω	680 / 750 Ω *
One 30mA, 1.5V. Bulb	330 / 360 Ω *	430 Ω *	470 / 510 Ω *
One 15mA, 1.5V. Bulb	680 / 750 Ω	820 / 910 Ω	1000 / 1100 Ω
Two 15mA, 12V. Bulbs in parallel	0 Ω	43 / 47 Ω	110 / 120 Ω
Two 20mA, 3.4V. White LEDs in series	220 / 270 Ω	330 / 360 Ω	430 / 470 Ω
Two 20mA, 2V. Colored LEDs in series	360 / 430 Ω	470 / 510 Ω	620 Ω
Two 15mA, 1.5V. Bulbs in series	560 / 620 Ω	750 Ω	820 / 910 Ω
Three 20mA, 3.4V. White LEDs in series	51 / 56 Ω	160 / 180 Ω	270 / 300 Ω
Three 20mA, 2V. Colored LEDs in series	270 / 300 Ω	360 / 430 Ω	470 / 510 Ω



Simple

Programming

WORKSHEET INSTRUCTIONS

TCS decoder programming is organized into tables. Each table is labeled and numbered to indicate which feature it controls. Generally all choices that need to be made to operate a feature are in that table. In a few cases, a choice made for one feature will interact with another. In that case, you will be directed to the other table number.

- A blank outlined box is provided by each CV number. This is so you can preplan your decoder and have a place to record your choices.
- In many cases you are choosing a single number such as an address, a rate, or a limit.
- In some cases you are choosing more than one value to activate more than one action, function, or button. Each of your possible choices will have a value. Add the values of the choices you want active and enter that sum in the blank box.
- The other box by the CV number is the factory set value. If it is shaded, it can be reset with Factory Reset (Table 20). When you reset, you reset all of the values in shaded boxes.

The cover pages provide general information to aid in decoder installation. The interior pages provide programming tables for features rarely used or modified.

The worksheet supplied with your decoder provides information that is specific to that decoder and all the programming tables that are normally used.

Contact TCS at: P.O. Box 341, 845 Blooming Glen Rd., Blooming Glen, PA 18911
Phone 215-453-9145 Fax 215-257-0735 Email tcs@ot.com Web www.tcsdcc.com

ADDRESSING

Decoder Lock Same address decoders need a different sub address in CV 16.

5	To unlock a decoder, make CV 15 = 0 or CV 15 = CV 16. To lock a decoder, make CV 15 not equal to CV 16. To lock all same address decoders, make CV 15 = 7.									
	CV 15	0		All unlocked = 0	Decoder to unlock = 1 - 6	All locked = 7				
	CV 16	1		Mobil = 1	Sound = 2	Light Only = 3	___ = 4	___ = 5	___ = 6	

MOTOR CONTROL

Variable Momentum Create speed curves more realistic to actual conditions.

7	Values greater than 0 in all CVs create compound curves.									
	CV 132	0	12	Acceleration Rate 3	RATE 3	→	→	→	→	→
	CV 131	0	130	Rate 3 starting point						
	CV 130	0	20	Acceleration Rate 2						
	CV 129	0	90	Rate 2 starting point	RATE 2	→	→	→	→	→
	CV 3	0	70	Acceleration Rate 1						
	CV 128	0	20	Deceleration Rate 3	RATE 3	→	→	→	→	→
	CV 127	0	150	Rate 3 ending point						
	CV 126	0	40	Deceleration Rate 2						
	CV 125	0	110	Rate 2 ending point	RATE 2	→	→	→	→	→
CV 4	0	60	Deceleration Rate 1							

Button Control of the Motor Circuit Use the engine for high speed switching or connect a smoke unit or other high power function (1.2A). Manual Control uses button 2 for forward and button 3 for reverse. Automatic Control uses button 2 for on/off and engine reverse for direction.

8	CV 61	0		Not Used = 0	Manual Control = 64	Automatic Control = 68
	CV 133	255		Constant Circuit Power	0 = off, 255 = full power	

Add any value in CV 61 to any additional value in Table 13, CV 61.

Loadable Speed Tables Make sure Table 1 "D" equals 16.

9	When Table 1 "B" equals 0, use only the Shaded CVs.										
	CV 67	2		CV 74	30		CV 81	72		CV 88	135
	CV 68	5		CV 75	35		CV 82	79		CV 89	147
	CV 69	7		CV 76	40		CV 83	84		CV 90	161
	CV 70	12		CV 77	47		CV 84	93		CV 91	177
	CV 71	16		CV 78	51		CV 85	100		CV 92	196
	CV 72	21		CV 79	58		CV 86	112		CV 93	219
	CV 73	26		CV 80	65		CV 87	121		CV 94	255

Momentary Pulse Control A light, activate decoders, or activate a function.

12	CV 62	60		Pulse Width = 0 to 4 seconds (1 second = 60, 4 seconds = 255)
----	-------	----	--	---

Mars/Gyra Light Control You can't use Mars and Gyra Lights at the same time.

15	Modify the effects of your light. All values must be greater than 0.									
	CV 113	9		Max. Bright Time	→	→	→	→	→	→
	CV 116	22		Max. Brightness						
	CV 115	6		Mid Brightness						
	CV 112	1		Min. Brightness						
	CV 114	1		Total Light Cycle						

Rotary Beacon Light Control

16	Modify the effects of your light. All values must be greater than 0.									
	CV 119	2		Max. Bright Time	→	→	→	→	→	→
	CV 122	8		Max. Brightness						
	CV 121	4		Mid Brightness						
	CV 118	2		Min. Brightness						
	CV 120	3		Total Light Cycle						

CONVENIENCE

Function Remapping Choose the values for the buttons to activate a function.

Buttons	Fwd	0	Rev	1	2	3	4	5	6	7	8	9	10	11	12
Value	1	2	4	8	16	32	64	128	4	8	16	32	64	128	
CV 33	1														
CV 34	2														
CV 35	4									(7-12)	0	CV 37			
CV 36	8									(7-12)	0	CV 38			
CV 39	16									(7-12)	0	CV 41			
CV 40	32									(7-12)	0	CV 42			
CV 134	2														
CV 123	32														
CV 124	8														

When using Ditch Lights, use the same button to turn on both ditch light wires.

Identification Numbers

21	CV 7	**		TCS Version of this decoder.
	CV 8	153		TCS Manufacturer's Identification Number
	CV 105	0		Identification provided for User.
	CV 106	0		Identification provided for User.

WARRANTY This decoder is covered by a one year goof proof, no questions asked replacement warranty. Send decoders in a padded envelope or small box directly to TCS. (If mailing, use the P.O. Box address, otherwise use the street address.) Please include your phone number, Email address, and street address when returning any items.